

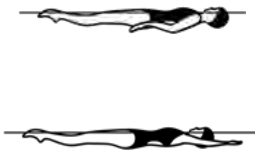
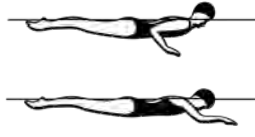
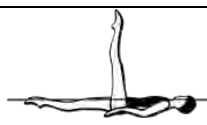
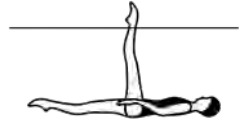

1. **APPENDICES**
 1.1 **Appendix 1 World Aquatics Basic Position, Basic Movement and Figures**

1.1.1 **Basic Body Position (BP)**

In all basic body positions:

- a) arm positions are optional,
- b) toes must be pointed, ankles must be extended,
- c) the legs, trunk and neck are fully extended unless otherwise specified and
- d) diagrams are a guide only. If there is a discrepancy between a diagram and a written description, the English written Body Position description prevails.

<p>1 BACK LAYOUT POSITION</p>	
<p>Body extended with face, chest, thighs and feet at the surface of the water. Head (ears specifically), hips and ankles in horizontal alignment.</p>	
<p>2 FRONT LAYOUT POSITION</p>	
<p>Body extended with head, upper back, buttocks and heels at the surface of the water. Unless otherwise specified, face may be in or out of the water.</p>	
<p>3 BALLET LEG POSITION</p>	
<p>a) Surface Body in Back Layout Position. One leg extended perpendicular to the surface of the water</p>	
<p>b) Submerged Head, trunk and horizontal leg parallel to the surface of the water. One leg perpendicular to the surface with the water level between the knee and the ankle.</p>	
<p>4 FLAMINGO POSITION</p>	

<p>a) Surface</p> <p>One leg extended perpendicular to the surface of the water. The other leg bent with the mid-calf opposite the vertical leg. Foot, shin and knee at and parallel to the surface of the water. Face at the surface of the water.</p>	
<p>b) Submerged</p> <p>Trunk, head, shin and foot of the bent leg parallel to the surface of the water. 90° angle between the trunk and extended leg.</p> <p>Water level between knee and ankle of the extended leg.</p>	

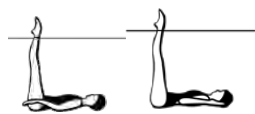

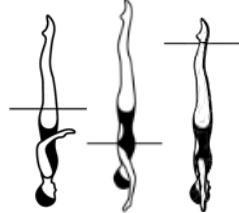
<p>5 BALLET LEG DOUBLE POSITION</p>	
<p>a) Surface</p> <p>Legs together and extended perpendicular to the surface of the water. Head in line with the trunk. Face at the surface of the water.</p>	
<p>b) Submerged</p> <p>Trunk and head parallel to the surface of the water. 90° angle between the trunk and the extended legs. Water level between knees and ankles of the extended legs.</p>	

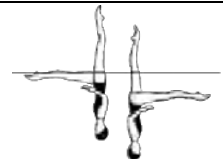

<p>6 VERTICAL POSITION</p>	
<p>Body extended perpendicular to the surface of the water; legs together, head downward. Head (ears specifically), hips and ankles in line</p>	

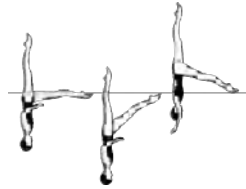

<p>7 CRANE POSITION – this position is currently not performed in any World Aquatics figure.</p>	
<p>Body extended in Vertical Position with one leg extended forward at a 90° angle to the body</p>	

<p>8 FISHTAIL POSITION</p>	
-----------------------------------	--

<p>Body extended in Vertical Position with one leg extended forward. The foot of the forward leg is at the surface of the water regardless of the height of the hips.</p>		
---	---	--



<p>9 TUCK POSITION</p> <p>Body as compact as possible, with the back rounded and the legs together. Heels close to buttocks. Head close to knees</p>		
---	---	---

<p>10 FRONT PIKE POSITION</p> <p>Body bent at hips to form a 90° angle. Legs extended and together. Trunk extended with the back straight and head in line.</p>		
--	---	---

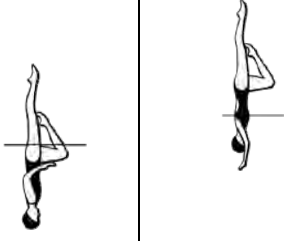

<p>11 BACK PIKE POSITION</p> <p>Body bent at hips to form an acute angle of 45° or less. Legs extended and together. Trunk extended with the back straight and head in line.</p>		
---	---	---

<p>13 SURFACE ARCH POSITION</p> <p>Lower back arched with hips, shoulders and head on a vertical line. Legs together and at the surface of the water.</p>		
--	---	--

<p>14 BENT KNEE POSITIONS</p> <p>Body in Front Layout, Back Layout, Vertical, or Arched Positions. One leg bent, with the toe of the bent leg in contact with the inside of the extended leg at the knee or higher.</p> <p>a) Bent Knee Front Layout Position</p> <p>Body extended in Front Layout Position with the thigh of the bent leg perpendicular to the surface of the water. Unless otherwise specified face may be in or out of the water.</p>		
--	---	--

<p>b) Bent Knee Back Layout Position</p> <p>Body extended in Back Layout Position. The thigh of the bent leg is perpendicular to the surface of the water.</p>	
<p>c) Bent Knee Vertical Position</p> <p>Body extended in Vertical Position with the thigh of the bent leg parallel to the surface of the water.</p>	
<p>d) Bent Knee Surface Arch Position</p> <p>Lower back arched with hips, shoulders and head on a vertical line. The thigh of the bent leg is perpendicular to the surface of the water</p>	

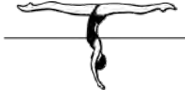

<p>15 TUB POSITION</p>	
<p>Legs bent and together, feet and shins at and parallel to the surface of the water with thighs perpendicular. Head in line with trunk. Face at the surface of the water.</p>	

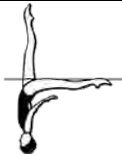
16 SPLIT POSITION	
Legs evenly split forward and back. The legs are parallel to the surface of the water. Lower back arched, with hips, shoulders and head on a vertical line. 180° angle between the extended legs (flat split), with inside of each leg aligned on opposite sides of a horizontal line, regardless of the height of the hips.	
a) Surface Split Position Legs are dry at the surface of the water.	
b) Airborne Split Position Legs are above the surface of the water	

17 KNIGHT POSITION	
Lower back arched, with hips, shoulders and head on a vertical line. One leg vertical. Other leg extended backward with the leg at the surface of the water and as close to horizontal as possible.	

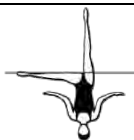
18 KNIGHT VARIANT POSITION	
Lower back arched, with hips, shoulders and head on a vertical line. One leg vertical. The other leg is behind the body with the knee bent at an angle of 90° or less. The thigh and shin of the bent leg are parallel to the surface of the water.	

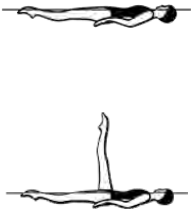
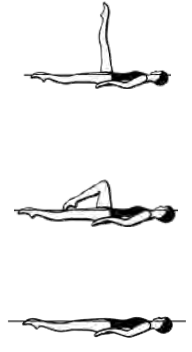
19 SIDE FISHTAIL POSITION	
Body extended in Vertical Position with one leg extended sideways with the foot at the surface of the water regardless of the height of the hips	

<p>1 TO ASSUME A BALLET LEG / A BALLET LEG IS ASSUMED</p>	
<p>Begin in a Back Layout Position. One leg remains at the surface of the water throughout. The foot of the other leg is drawn along the inside of the extended leg to assume a Bent Knee Back Layout Position. The bent leg is straightened without movement of the thigh to assume a Ballet Leg Position.</p>	
<p>1B TO ASSUME A STRAIGHT BALLET LEG / A STRAIGHT BALLET LEG IS ASSUMED</p>	
<p>From a Back Layout Position one leg is raised straight to a Ballet Leg Position.</p>	
<p>2 TO LOWER A BALLET LEG / THE BALLET LEG IS LOWERED</p>	
<p>From a Ballet Leg Position the ballet leg is bent without movement of the thigh to a Bent Knee Back Layout Position. The toe moves along the inside of the extended leg until a Back Layout Position is assumed.</p>	
<p>3 TO ASSUME A FRONT PIKE POSITION / A FRONT PIKE POSITION IS ASSUMED</p>	
<p>From a Front Layout Position with the face in the water the trunk moves downward to assume a Front Pike Position. The buttocks, legs and feet travel along the surface of the water until the hips occupy the position of the head at the beginning of this action</p>	

<p>4 TO ASSUME A SUBMERGED BALLET LEG DOUBLE POSITION FROM A FRONT PIKE POSITION/A SUBMERGED BALLET LEG DOUBLE POSITION IS ASSUMED</p>	
<p>While maintaining a Front Pike Position the body somersaults forward around a lateral axis as the buttocks, legs and feet move downward. The hips replace the head to assume a Submerged Ballet Leg Double Position.</p>	

<p>5 ARCH TO BACK LAYOUT POSITION</p>	
<p>From a Surface Arch Position the hips, chest and face surface sequentially at the same point with foot first movement to a Back Layout Position until the head occupies the position of the hips at the beginning of this action.</p>	

<p>6 WALKOUTS</p>	
<p>These movements start in a Split Position unless otherwise specified in the figure description. The hips remain stationary as one leg is lifted in an arc over the surface of the water to meet the opposite leg.</p>	

a) Walkout Front

The front leg is lifted in a 180° arc over the surface of the water to meet the opposite leg in a **Surface Arch Position** and with continuous movement an *Arch to Back Layout Finish Action* is executed.

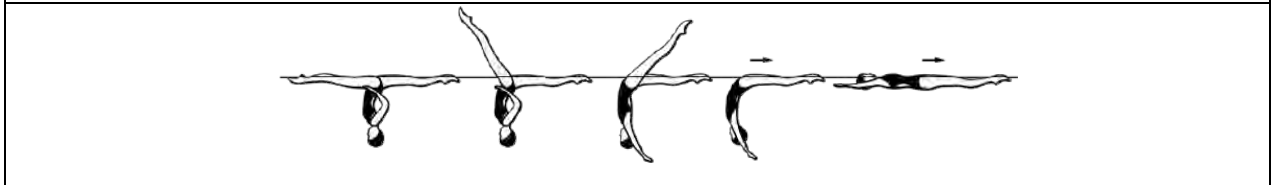

b) Walkout Back

The back leg is lifted in a 180° arc over the surface of the water to meet the opposite leg in a **Front Pike Position** and with continuous movement the body straightens to a **Front Layout Position**. The head surfaces at the position occupied by the hips at the beginning of this action.

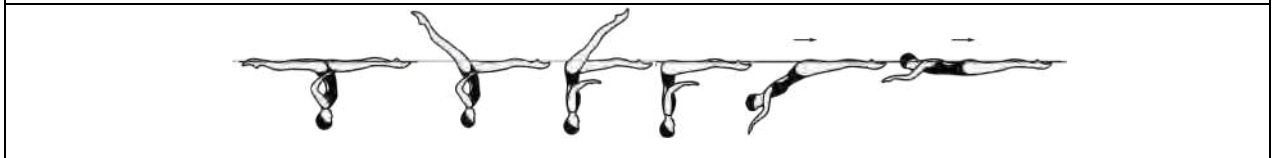

7 CATALINA ROTATION

From a **Ballet Leg Position** a rotation of the body is initiated. The head, shoulders and trunk begin the rotation at the surface of the water while descending without lateral movement to a **Fishtail Position**. The vertical leg remains perpendicular to the surface of the water while the foot of the horizontal leg remains at the surface of the water throughout the rotation. Unless otherwise specified, *Catalina Rotation* starts from a **Ballet Leg Position**.

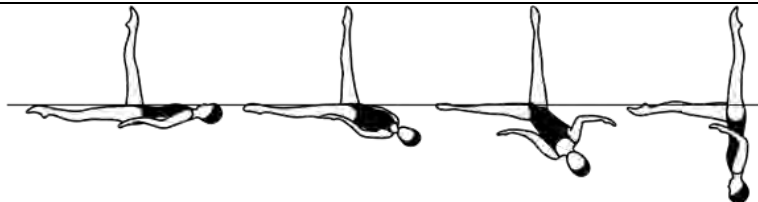

8 CATALINA REVERSE ROTATION

From a **Fishtail Position** the hips rotate as the trunk rises without lateral movement to assume a **Ballet Leg Position**. The vertical leg remains perpendicular to the surface of the water while the foot of the horizontal leg remains at the surface of the water throughout the rotation.

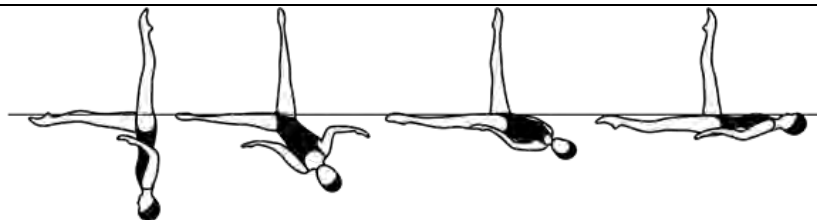

9 THRUST		
<p>From a Submerged Back Pike Position with the legs perpendicular to the surface of the water a vertical upward movement of the legs and hips is rapidly executed as the body unrolls to assume a Vertical Position. Maximum height desirable.</p>		
<p>THRUST ALLOWANCE Deviation allowances for the <i>Thrust</i> action are unique and allow for the legs to be (up) to an additional 15 degrees of the vertical line.</p>		
Deductions are as follows :		
	Angle Deviation	Deduction Amount
Small Deviation	0 – 30 degrees	0.2
Medium Deviation	31 – 44 degrees	0.5
Large Deviation	45 degrees or more	1.0

10 VERTICAL DESCENT	
<p>Maintaining a Vertical Position the body descends along its longitudinal axis until the toes are submerged.</p>	

11 ROCKET SPLIT	
<p>A <i>Thrust</i> is executed to a Vertical Position. Maintaining maximum height the legs are split simultaneously and rapidly to assume an Airborne Split Position and rejoin to a Vertical Position, followed by a <i>Vertical Descent</i>. The <i>Vertical Descent</i> is executed at the same tempo as the <i>Thrust</i>.</p>	

12 TWISTS

A *Twist* is a rotation at a sustained height. The body remains on its longitudinal axis throughout the rotation. Unless otherwise specified when performed in a **Vertical Position** a *Twist* is completed with a *Vertical Descent*.

a) *Half Twist*:

a *Twist* of 180°

b) *Full Twist*:



a *Twist* of 360°

c) **A Twirl**:



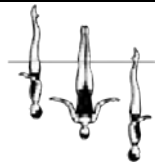
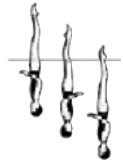

a rapid *Twist* of 180°

Twist Allowance

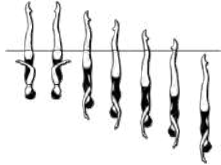
The acceptable allowance for *Twist* rotations (*Half Twist*, *Full Twist* and *Twirl*) is up to ¼ less than/more than the required rotation.

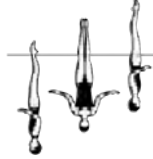
13 SPINS	
<p>A <i>Spin</i> is a rotation in a Vertical Position. The body remains on its longitudinal axis throughout the rotation. Unless otherwise specified <i>Spins</i> are executed in uniform motion and are completed with a <i>Vertical Descent</i> executed at the same tempo as the <i>Spin</i>.</p> <p>A <i>descending Spin</i> must start at the height of the vertical and be completed as the ankle(s) reach(es) the surface of the water. Unless otherwise specified a <i>descending Spin</i> is completed with a <i>Vertical Descent</i> which is executed at the same tempo as the <i>Spin</i>.</p>	
<p>d) 180° <i>Spin/Spinning</i> 180°: a <i>descending Spin</i> with a rotation of 180°</p>	
<p>e) 360° <i>Spin/Spinning</i> 360°: a <i>descending Spin</i> with a rotation of 360°.</p>	
<p>f) <i>Continuous Spin</i>: a <i>descending Spin</i> with a rapid rotation of: 720° (2), 1080° (3), or 1440° (4) which is completed as the ankles reach the surface of the water and continues through submergence. Continuous Spin 720° shown →</p>	

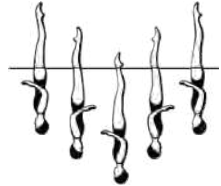
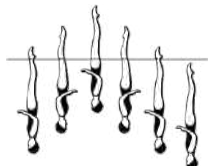
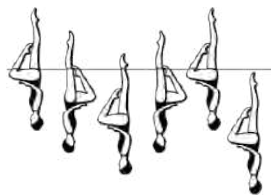
<p>g) <i>Twist Spin</i>: a <i>Half Twist</i> is executed and without a pause is followed by a <i>Continuous Spin</i> of 720° (2) performed in the same direction as the <i>Half Twist</i>.</p>	
--	---

<p>13 SPINS (cont.)</p>	
<p>An <i>ascending Spin</i> begins with the water level at the ankles unless otherwise specified. A vertical upward <i>Spin</i> is executed until a water level is established between the knees and hips. An <i>ascending Spin</i> is finished with a <i>Vertical Descent</i>.</p>	
<p>h) <i>Spin Up 180°</i>: an <i>ascending Spin</i> with a rotation of 180°</p>	
<p>i) <i>Spin Up 360°</i>: an <i>ascending Spin</i> with a rotation of 360°.</p>	
<p>j) <i>Combined Spin</i>: a <i>descending Spin</i> of at least 360° followed without a pause by an equal <i>ascending Spin</i> in the same direction. The <i>ascending Spin</i> reaches the same height where the <i>descending Spin</i> started.</p>	
<p>k) <i>Reverse Combined Spin</i>: an <i>ascending Spin</i> of at least 360° followed without a pause by an equal <i>descending Spin</i> in the same direction.</p>	
<p>l) <i>Bent Knee Combined Spin</i>: a <i>descending Spin</i> in a Bent Knee Vertical Position of at least 360° followed without a pause by an equal <i>ascending Spin</i> in the same direction in a Bent Knee Vertical Position. The <i>ascending Spin</i> reaches the same height where the <i>descending Spin</i> started.</p>	
<p>m) <i>Reverse Bent Knee Combined Spin</i>: an <i>ascending Spin</i> in a Bent Knee Vertical Position of at least 360° followed without a pause by an equal <i>descending Spin</i> in the same direction in a Bent Knee Vertical Position.</p>	

Spin Allowance

1. The acceptable allowance for a *Continuous Spin* is up to 180° less than/more than the required rotation.
2. The acceptable allowance for other *Spins (180° Spin, 360° Spin, 720° Spin, Twist Spin, Spin Up 180°, Spin Up 360°)* is up to ¼ less than/more than the required rotation

14. TO ASSUME A SURFACE ARCH POSITION / A SURFACE ARCH POSITION IS ASSUMED

From a **Back Layout Position** with the head leading, the head, hips and feet move along the surface of the water. With continuous movement the head leaves the surface of the water as the back is arched more to assume a **Surface Arch Position** with the hips occupying the position of the head at the beginning of this action

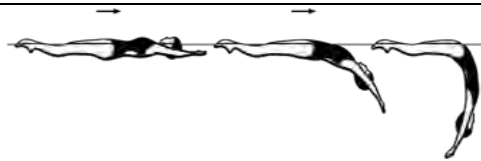

15 TO ASSUME A BENT KNEE SURFACE ARCH POSITION / A BENT KNEE SURFACE ARCH POSITION IS ASSUMED

From a **Back Layout Position** with the head leading, the head, hips and feet move along the surface of the water. With continuous movement the head leaves the surface of the water as the back is arched more to assume a **Bent Knee Surface Arch Position** with the hips occupying the position of the head at the beginning of this action

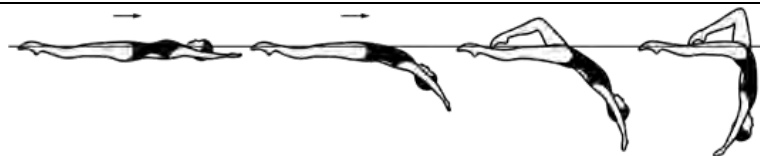

16 ARIANA ROTATION

From a **Split Position** maintaining the relative position of the legs to the surface of the water the hips rotate 180°.



17 HELICOPTER ROTATION

From a **Fishtail Position** the horizontal leg is lifted while closing into the vertical leg to assume a **Vertical Position** during a descending rotation and is completed as the ankles reach the surface of the water

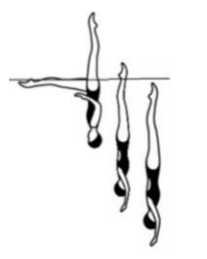
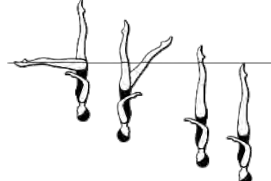
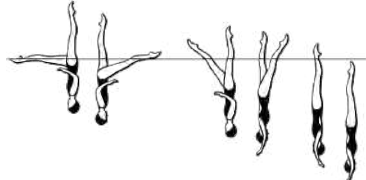
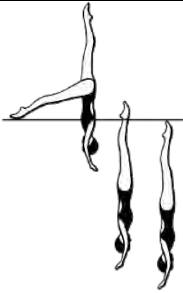
<p>a) <i>Spinning 180°: A descending Spin with a rotation of 180° completed with a Vertical Descent.</i></p>	
<p>b) <i>Spinning 360°: A descending Spin with a rotation of 360° completed with a Vertical Descent.</i></p>	
<p>c) <i>Continuous Spin 720°: a descending Spin with a rapid rotation of: 720° (2), completed as the ankles reach the surface of the water and continues through submergence.</i></p>	
<p>d) <i>Rapid Airborne Spinning 180°: from an airborne Fishtail Position the horizontal leg is rapidly lifted while closing into the vertical leg to Vertical Position during a rapid descending Spin with a rotation of 180° and is completed as the ankles reach the surface of the water followed by a rapid Vertical Descent.</i></p>	

<p>18 FOUETTÉ ROTATION</p>	
<p>From a Fishtail Position with the horizontal leg leading toward the vertical leg a rapid 180° rotation is executed as the front leg bends to assume a Bent Knee Vertical Position. The bent leg rapidly extends to a Fishtail Position.</p>	

1.1.3 12 and Under Figures

Group & Figure #	Figure Name	DD
Compulsory		
106	Straight Ballet Leg	1.6
301	Barracuda	1.8

Optional Groups:		
Group 1		
359	Front Ariana	2.2
348	Tower	1.9
Group 2		
363	Water Drop	1.8
401	Swordfish	2.1

Group 3		
311	Kip	1.6
227d	Swanita Spinning 180°	1.9

1.1.3.1 **Compulsory:**

1- **106 Straight Ballet leg**

DD 1.6

A straight Ballet Leg is Assumed. The Ballet Leg is lowered.







				Total
NVT=	18.5	11.0	10.5	40
PV =	4.63	2.75	2.63	10

2- **301 Barracuda**

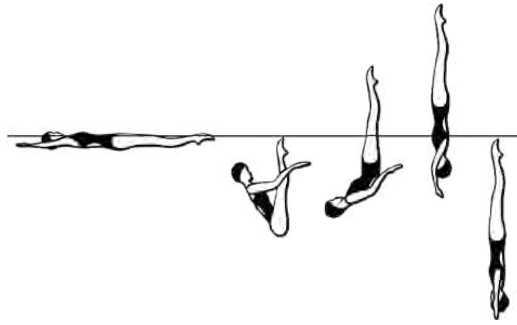
DD 1.8

From a **Back Layout Position** the legs are raised to vertical as the body is submerged to a **Back Pike Position** with the toes just under the surface of the water. A *Thrust* is executed to a **Vertical Position**. A *Vertical Descent* is executed at the same tempo as the *Thrust*.



				Total
NVT=	7.0	31.0	13.0	51
PV =	1.37	6.08	2.55	10

1.1.3.2 Optional Groups





1.1.3.2.1 Group 1

3- 359 Front Ariana

DD 2.2

From a Front Layout Position a *Front Pike Position* is assumed. One leg is lifted in a 180° arc over the surface of the water to a Split Position. Maintaining the relative position of the legs to the surface of the water, an *Ariana Rotation* is performed. A *Walkout Front* is executed.







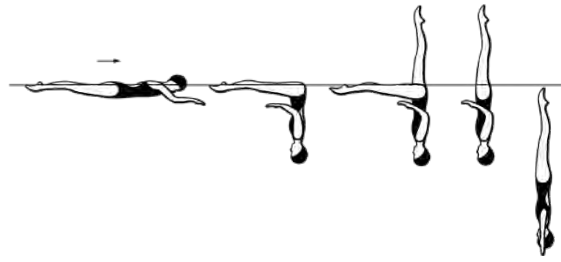

					Total
NVT=	6.0	20.0	17.0	23.0	73
PV =	0.82	2.74	2.33	3.15	10

4- 348 Tower

DD 1.9

From a **Front Layout Position** a Front Pike Position is assumed. One leg is lifted to a **Fishtail Position**. The horizontal leg is lifted to a **Vertical Position**. A Vertical Descent is executed.



					Total
NVT=	6.0	14.5	20.5	14.0	55
PV =	1.09	2.64	3.73	2.55	10





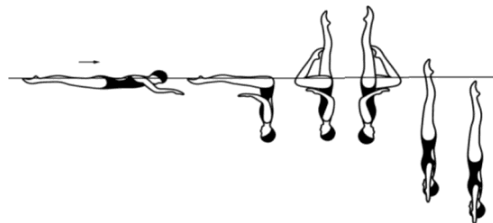

1.1.3.2.2 **Group 2**

3- 363 Water Drop

DD 1.8

From a **Front Layout Position** a *Front Pike Position* is assumed. The legs are lifted simultaneously to a **Bent Knee Vertical Position**. A *Half Twist* is executed. A *180° Spin* is executed in the same direction as the bent leg is extended to a **Vertical Position** and completed as the ankles reach the surface of the water. A *Vertical Descent* is executed.







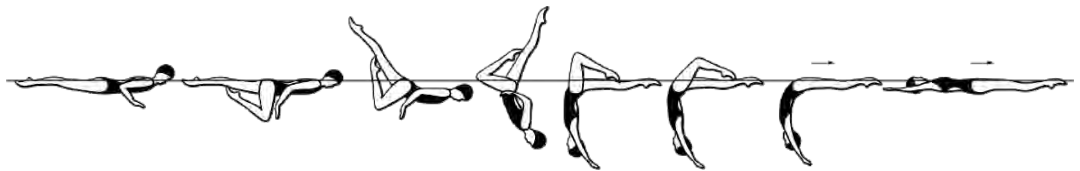

						Total
NVT=	6.0	15.0	15.0	13.0	0	49
PV =	1.22	3.06	3.06	2.65	0	10

4- 401 Swordfish

DD 2.1

From a **Front Layout Position** a **Bent Knee Front Layout Position** is assumed. The back arches more as the extended leg is lifted in a 180° arc over the surface of the water to assume a **Bent Knee Surface Arch Position**. The bent leg is straightened to assume a **Surface Arch Position**. With continuous motion an *Arch to Back Layout Finish Action* is executed.



					Total
NVT=	4.0	47.0	11.5	7.0	69.5
PV =	0.58	6.76	1.65	1.01	10

1.1.3.2.3

Group 3





3- 311 Kip

DD 1.6

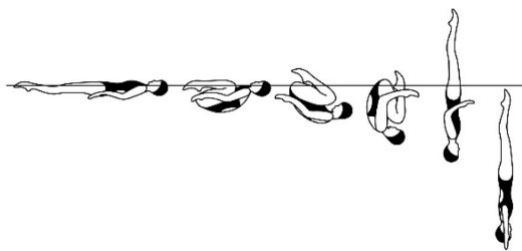
From a **Back Layout Position** the knees, shins and toes are drawn along the surface of the water to assume a **Tuck Position**. With continuous motion the tuck becomes more compact and a partial Somersault Back Tuck is executed until the shins are perpendicular to the surface of the water. The trunk unrolls as the legs are straightened to assume a **Vertical Position** midway between the

former vertical line through the hips and the former vertical line through the head and shins. A *Vertical Descent* is executed.







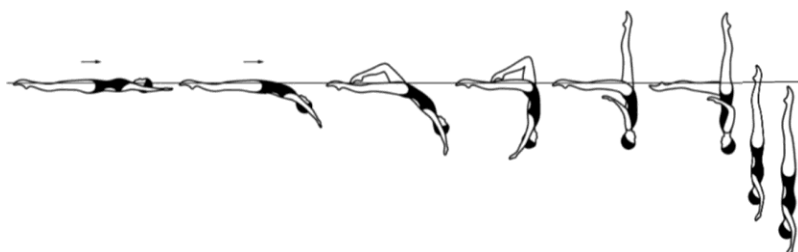

					Total
NVT=	3.0	2.0	23.0	14.0	
PV =	0.71	0.48	5.48	3.33	10

4- 227d Swanita Spinning 180°

DD 1.9

From a **Back Layout Position** a *Bent Knee Surface Arch Position* is assumed. The bent leg straightens to assume a **Knight Position**. The body rotates 180° to assume a **Fishtail Position**. Continuing in the same direction a descending *Spinning 180°* rotation is executed as the horizontal leg is lifted to a **Vertical Position** and is completed as the ankles reach the surface of the water. A *Vertical Descent* is executed.



						Total
NVT=	17.5	14.0	14.0	12.5	0	
PV =	3.02	2.41	2.41	2.16	0	10

1.1.4

Youth Figures / 13-15 Figures

Group & Figure #	Figure Name	DD
Section A		
Group 1		
140g	Flamingo Bent Knee, Twist Spin	2.9
437	Cyclone, Open 180°	2.6
Group 2		
308h	Barracuda Airborne Split Spin Up 180°	2.9
407	Swordfish Straight Leg Ariana Rotation	2.6
Section B		
Group 3		
356f	Whip Continuous Spin 720°	3.0
441	Saturn	2.5
Group 4		
352	Venus	3.0
240i	Albatross Spin up 360°	2.5
Section C		
Group 5		
144	Rio Straight Leg	3.1
421	Walkover Back Closing 360°	2.4
Group 6		
440d	Ipanema Spinning 180°	3.1
311j	Kip Combined Spin	2.4

1.1.4.1 Section A

1.1.4.1.1 Group 1

1- 140g Flamingo Bent Knee, Twist Spin

DD 2.9

A Ballet Leg is assumed. The shin of the horizontal leg is drawn along the surface of the water to assume a **Surface Flamingo Position**. With the ballet leg maintaining its vertical position the hips are lifted as the trunk unrolls while the bent leg moves to a **Bent Knee Vertical Position**. The bent leg is extended to a **Vertical Position**. A *Twist Spin* is executed.

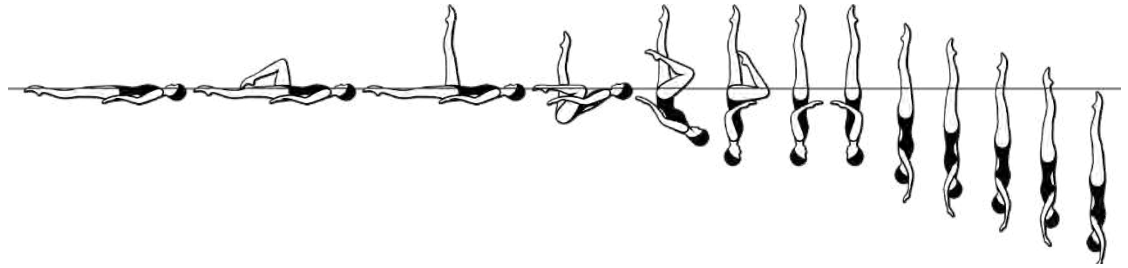

								Total
NVT=	10.5	11.0	7.5	20.0	16.5	48.0		113.5
PV =	0.93	0.97	0.66	1.76	1.45	4.23		10

2- 437 Cyclone, Open 180°

DD 2.6

From a **Back Layout Position** a **Bent Knee Surface Arch Position** is assumed. The legs are simultaneously lifted to a **Vertical Position** as a **Twirl** is executed. Continuing in the same direction the legs are opened symmetrically to a **Split Position** as a 180° rotation is executed. A **Walkout Front** is executed.

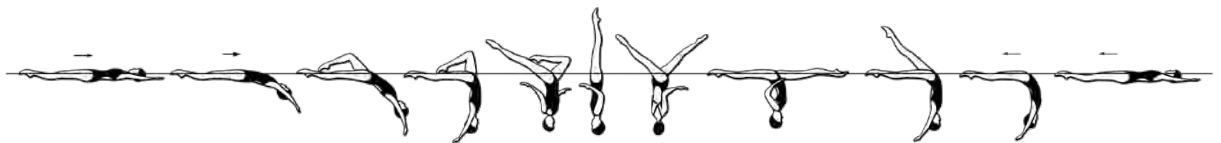

						Total
NVT=	17.5	29.0	20.0	23.0	7.0	96.5
PV =	1.81	3.01	2.07	2.38	0.73	10

1.1.4.1.2







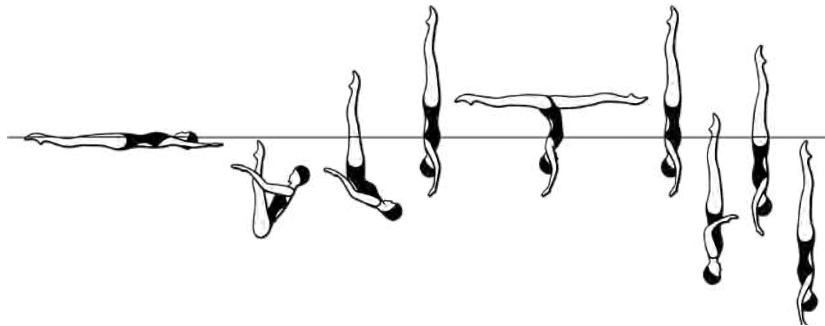

Group 2

1 - 308h Barracuda Airborne Split, Spin Up 180°

DD 2.9

From a **Back Layout Position** the legs are raised to a vertical as the body is submerged to a **Back Pike Position** with the toes just under the surface of the water. All remaining movements are performed rapidly. A **Rocket Split** is executed. A **Vertical Descent** is executed and is completed as the ankles reach the surface of the water. A **Spin Up 180°** is executed. A **Vertical Descent** is executed.







								Total
NVT=	7.0	31.0	17.0	13.0	13.0	20.0	13.0	114
PV =	0.61	2.72	1.49	1.14	1.14	1.75	1.14	10

2 - 407 Swordfish Straight Leg Ariana Rotation DD 2.6

From a **Front Layout Position** the back arches as one leg is lifted in a 180° arc over the surface of the water to a **Split Position**. Maintaining the relative position of the legs to the surface of the water an *Ariana Rotation* is performed. A *Walkout Front* is executed.



					Total
NVT=	48.0	17.0	23.0	7.0	95
PV =	5.05	1.79	2.42	0.74	10

1.1.4.2 Section B





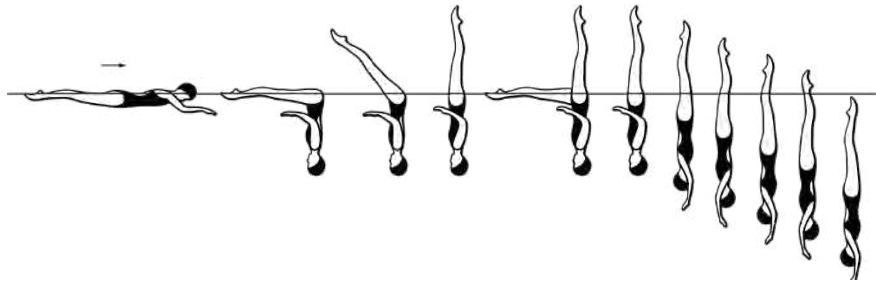

1.1.4.2.1 Group 3

1 - 356f Whip Continuous Spin 720°

DD 3.0

From a **Front Layout Position** a *Front Pike Position* is assumed. The legs are lifted to a **Vertical Position**. All remaining movements are performed rapidly. One leg is lowered to a **Fishtail Position** and without a pause is lifted to a **Vertical Position**. Without a pause a *Continuous Spin 720°* is executed.







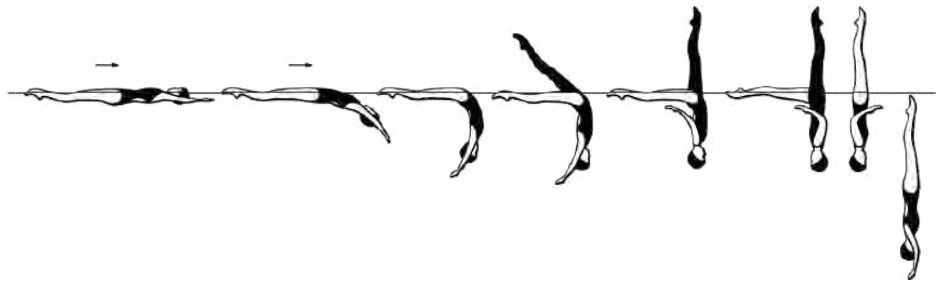

							Total
NVT=	6.0	33.0	22.5	20.5	34.0	0	116
PV =	0.52	2.84	1.94	1.77	2.93	0	10

2 - 441 Saturn

DD 2.5

From a **Back Layout Position** a *Surface Arch Position* is assumed. One leg is lifted to assume a **Knight Position**. Maintaining the vertical alignment the body rotates 180° to assume a **Fishtail Position**. Continuing in the same direction a *Twirl* is executed as the horizontal leg is lifted to a **Vertical Position**. A *Vertical Descent* is executed.



						Total
NVT=	12.0	23.5	14.0	23.5	14.0	87
PV =	1.38	2.70	1.61	2.70	1.61	10

28.1.4.2.1 Group 4

1 - 352 Venus

DD 3.0

From a **Front Layout Position** a *Front Pike Position* is assumed. All remaining movements are performed rapidly. One leg is lifted to a **Fishtail Position**. The horizontal leg is bent to assume a **Bent Knee Vertical Position**. The bent leg is extended to vertical as the vertical leg is lowered to become the horizontal leg in **Fishtail Position**. A rotation of 360° is executed in the **Fishtail Position**. The horizontal leg is lifted to a **Vertical Position**. A 360° *Spin* is executed.

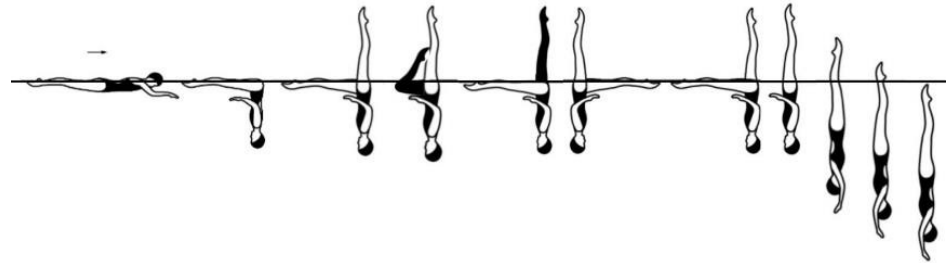







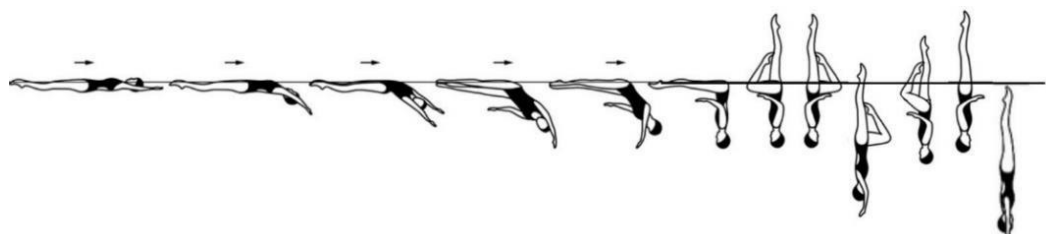

										Total
NVT=	6.0	12.5	12.5	18.5	24.0		20.5	23.0	0	117
PV =	0.51	1.07	1.07	1.58	2.05		1.75	1.97	0	10

2 - 240i Albatross Spin Up 360°

DD 2.5

From a **Back Layout Position** with the head leading, the head, hips and feet move along the surface of the water. The hips, legs and feet continue to move along the surface of the water as the body rolls onto the face and a *Front Pike Position* is assumed with the hips occupying the position of the head at the beginning of this action. The legs are lifted simultaneously to a **Bent Knee Vertical Position**. A *Half Twist* is executed. Maintaining a **Bent Knee Vertical Position**, a *Vertical Descent* is executed until the ankle of the extended leg reaches the surface of the water. A *Spin Up 360°* is executed as the bent leg is extended to **Vertical Position**. A *Vertical Descent* is executed.



							Total
NVT=	15.0	15.0	15.0	10.0	18.5	14.0	87.5
PV =	1.71	1.71	1.71	1.14	2.11	1.60	10

1.1.4.3 Section C





1.1.4.3.1 Group 5

1 - 144 Rio Straight Leg

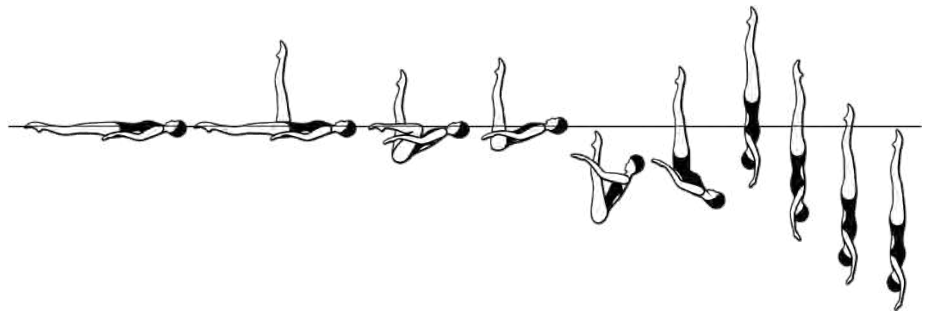
DD 3.1

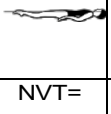
A *Straight Ballet Leg* is assumed. The knee, shin and toes of the horizontal leg are drawn along the surface of the water to assume a **Surface Flamingo Position**. The bent leg is straightened to a **Surface Ballet Leg Double Position**. The body submerges vertically to a **Back Pike Position** with the toes just under the surface of the water. A *Thrust* is executed to a **Vertical Position**. A *Spinning 360°* is executed at the same tempo as the *Thrust*.

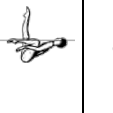
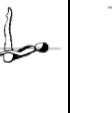
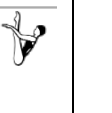
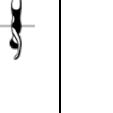





								Total
NVT=	18.5	7.5	13.0	12.0	31.0	39.0	0	121
PV =	1.53	0.62	1.07	0.99	2.56	3.22	0	10

2 - 421 Walkover Back Closing 360°

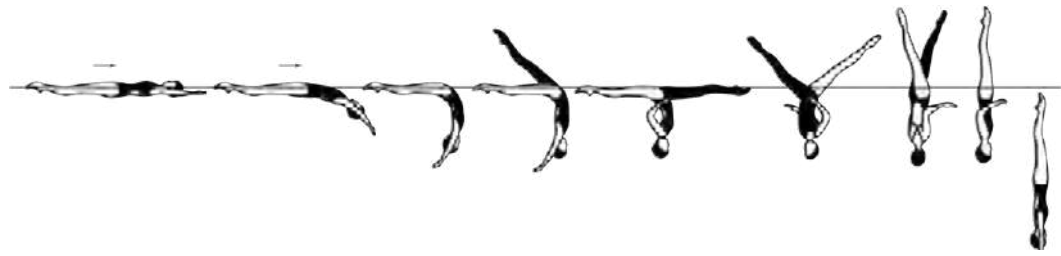
DD 2.4

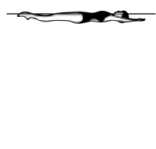
From a **Back Layout Position** a *Surface Arch Position* is assumed. One leg is lifted in a 180° arc over the surface of the water to a **Split Position**. With continuous motion a rotation of 360° is executed as the legs are symmetrically lifted and closed to a **Vertical Position**. A *Vertical Descent* is executed.



					Total
NVT=	12.0	29.0	27.0	14.0	
PV =	1.46	3.54	3.29	1.71	10





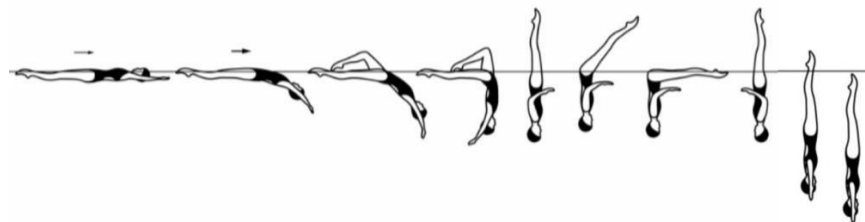

1.1.4.3.2 **Group 6**

1 - 440d Ipanema Spinning 180°

DD 3.1

From a **Back Layout Position** a *Bent Knee Surface Arch Position* is assumed. The horizontal leg is lifted to vertical as the bent leg is straightened to assume a **Vertical Position**. The legs are lowered to a **Front Pike Position**. A rapid 180° rotation is executed as the legs are lifted to a **Vertical Position**. Continuing in the same direction a rapid *180° Spin* is executed.







							Total
NVT=	17.5	21.0	33.0	33.0	16.0	0	120.5
PV =	1.42	1.70	2.67	2.67	1.54	0	10

2- 311j Kip Combined Spin (360° + 360°)

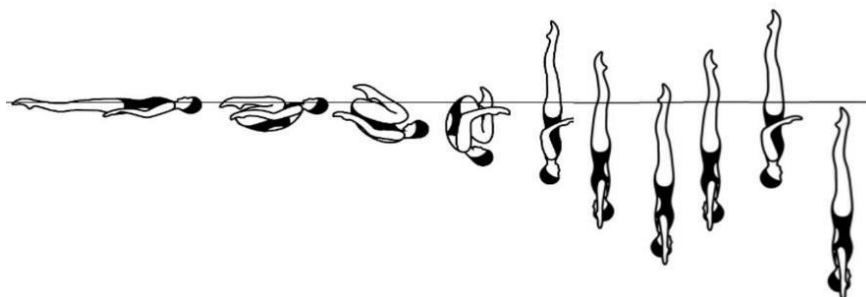
DD 2.4

From a **Back Layout Position** the knees, shins and toes are drawn along the surface of the water to assume a **Tuck Position**. With continuous motion the tuck becomes more compact and a partial Somersault Back Tuck is executed until the shins are perpendicular to the surface of the water. The trunk unrolls as the legs are straightened to assume a **Vertical Position** midway between the former vertical line through the hips and the former vertical line through the head and the shins. A rapid *Combined Spin* (360° + 360°) is executed followed by a rapid *Vertical Descent*.

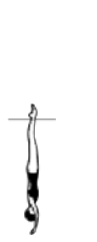
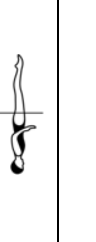
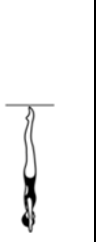

							Total
NVT=	3.0	2.0	23.0	40.0	14.0		82
PV =	0.37	0.24	2.80	4.88	1.71		10

1.2 Appendix 2 Technical Routines

1.2.1 General Requirements

In Olympic Games, Olympic Games Qualifier, Artistic Swimming World Cup, World Aquatics Artistic Swimming Championships and World Aquatics Junior Artistic Swimming Championships and other World Aquatics competitions as designated, Required Elements are used.

1. Unless otherwise specified in the description:
All required elements must be executed according to the requirements described in the World Aquatics AS Manual for Judges, Coaches and Referees.
2. If 1 or more competitors omits all or part of an element or performs an incorrect action in an element, refer to 2022-2025 World Aquatics Competition Regulations for penalties regarding incorrect or omitted actions.
3. Required Elements #1 - #5 can be performed in any order.
4. Required Elements #1 - #5 - It is required that the elements and the degrees of difficulty for each element selected to be performed, and the order of performance selected, must be declared and submitted on the Coach Card for the Technical Routine. This form must be submitted prior to the Competition/Event.
5. Additional hybrids and the degrees of difficulty for each hybrid selected, and the order to be performed, must be declared and submitted on the Coach Card for the Technical Routine. This form must be submitted prior to the Competition/Event.
6. With the exception of Deck Work, Entry, Hybrid Connected action (Mixed Duet), Acrobatic movement (Team), Pair Acrobatics (Duet and Mixed Duet), Cadence action (Team) and Circle Pattern (Team), Required and Free Elements and Transitions are to be performed simultaneously and facing same direction by all duet or team members.
7. Additional movements can be added immediately before and after (breath to breath) Required Elements #1 - #5. Those movements will not add any extra difficulty nor will be considered as the additional hybrids.
8. Time limits – refer to VII.14

Recommendation for all Technical Routines:

It is strongly recommended for clarity of judgment that Required Elements #1 - #5 are separated by other content.

1.2.2 Solo Required Elements

Element 1

1A - Thrust Continuous Spin 720° DD – 2.7

From a **Submerged Back Pike Position**, with the legs perpendicular to the surface, a *Thrust Continuous Spin 720°* (2 rotations) is executed.

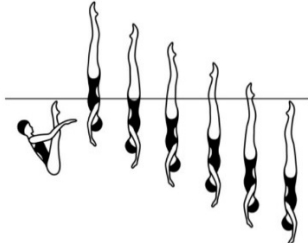

1B - Thrust Spinning 360°

DD - 2.1

From a **Submerged Back Pike Position**, with the legs perpendicular to the surface, a *Thrust Spinning 360°* (1 rotation) is executed.

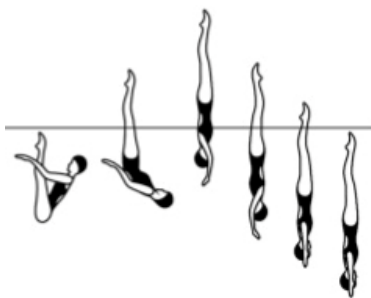

Element 2

2A – Combined Spin 1080° – Continuous Spin 1080°

DD - 3.0

From a **Vertical Position** a *Combined Spin of 1080°* is executed (3 rotations + 3 rotations). Continuing in the same direction and without a pause a *Continuous Spin 1080°* (3 rotations) is executed.

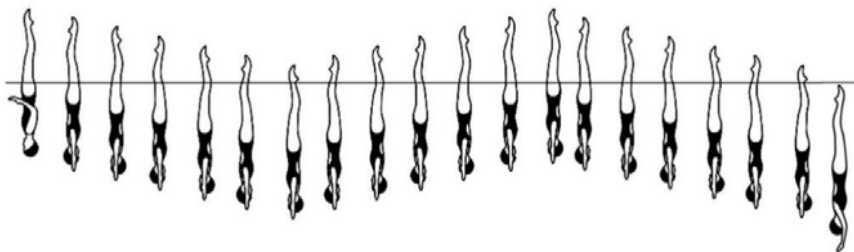

2B – Combined Spin 720° – Continuous Spin 1080°

DD - 2.7

From a **Vertical Position** a *Combined Spin of 720°* is executed (2 rotations + 2 rotations). Continuing in the same direction and without a pause a *Continuous Spin 1080°* (3 rotations) is executed.

